

Keysight M9217A PXIe 2-CH Digitizer, Isolated, ± 256 V, 20 MSa/s, 16-Bit

Inspection, verification, and
installation for M9217A PXIe 2-CH
digitizer

Notices

© Keysight Technologies 2015

No part of this manual may be reproduced in any form or by any means (including electronic storage and retrieval or translation into a foreign language) without prior agreement and written consent from Keysight Technologies as governed by United States and international copyright laws.

Manual Part Number

M9217-90001

Edition

Edition 1, October 1, 2015

Keysight Technologies
1400 Fountaingrove Parkway
Santa Rosa, CA 95403

Sales and Technical Support

To contact Keysight for sales and technical support, refer to the "support" links on the following Keysight Web resources:

- www.keysight.com/find/m9217a
(product-specific information and support, software and documentation updates)
- www.keysight.com/find/assist
(worldwide contact information for repair and service)

Information on preventing damage to your Keysight equipment can be found at www.keysight.com/find/tips.

Warranty

THE MATERIAL CONTAINED IN THIS DOCUMENT IS PROVIDED "AS IS," AND IS SUBJECT TO BEING CHANGED, WITHOUT NOTICE, IN FUTURE EDITIONS. FURTHER, TO THE MAXIMUM EXTENT PERMITTED BY APPLICABLE LAW, KEYSIGHT DISCLAIMS ALL WARRANTIES, EITHER EXPRESS OR IMPLIED WITH REGARD TO THIS MANUAL AND ANY INFORMATION CONTAINED HEREIN, INCLUDING BUT NOT LIMITED TO THE IMPLIED WARRANTIES OF MERCHANTABILITY AND FITNESS FOR A PARTICULAR PURPOSE. KEYSIGHT SHALL NOT BE LIABLE FOR ERRORS OR FOR INCIDENTAL OR CONSEQUENTIAL DAMAGES IN CONNECTION WITH THE FURNISHING, USE, OR PERFORMANCE OF THIS DOCUMENT OR ANY INFORMATION CONTAINED HEREIN. SHOULD KEYSIGHT AND THE USER HAVE A SEPARATE WRITTEN AGREEMENT WITH WARRANTY TERMS COVERING THE MATERIAL IN THIS DOCUMENT THAT CONFLICT WITH THESE TERMS, THE WARRANTY TERMS IN THE SEPARATE AGREEMENT WILL CONTROL.

Technology Licenses

The hardware and/or software described in this document are furnished under a license and may be used or copied only in accordance with the terms of such license.

Restricted Rights Legend

If software is for use in the performance of a U.S. Government prime contract or subcontract, Software is delivered and licensed as "Commercial computer software" as defined in DFAR 252.227-7014 (June 1995), or as a "commercial item" as defined in FAR 2.101(a) or as "Restricted computer software" as defined in FAR 52.227-19 (June 1987) or any equivalent agency regulation or contract clause. Use, duplication or disclosure of Software is subject to Keysight Technologies' standard commercial license terms, and non-DOD Departments and Agencies of the U.S. Government will receive no greater than Restricted Rights

as defined in FAR 52.227-19(c)(1-2) (June 1987). U.S. Government users will receive no greater than Limited Rights as defined in FAR 52.227-14 (June 1987) or DFAR 252.227-7015 (b)(2) (November 1995), as applicable in any technical data.

Safety Notices

CAUTION

A CAUTION notice denotes a hazard. It calls attention to an operating procedure, practice, or the like that, if not correctly performed or adhered to, could result in damage to the product or loss of important data. Do not proceed beyond a CAUTION notice until the indicated conditions are fully understood and met.

WARNING

A WARNING notice denotes a hazard. It calls attention to an operating procedure, practice, or the like that, if not correctly performed or adhered to, could result in personal injury or death. Do not proceed beyond a WARNING notice until the indicated conditions are fully understood and met.

The following safety precautions should be observed before using this product and any associated instrumentation.

This product is intended for use by qualified personnel who recognize shock hazards and are familiar with the safety precautions required to avoid possible injury. Read and follow all installation, operation, and maintenance information carefully before using the product. Refer to the user documentation for complete product specifications.

WARNING

If this product is not used as specified, the protection provided by the equipment could be impaired. This product must be used in a normal condition (in which all means for protection are intact) only.

The types of product users are:

- Responsible body is the individual or group responsible for the use and maintenance of equipment, for ensuring that the equipment is operated within its specifications and operating limits, and for ensuring that operators are adequately trained.
- Operators use the product for its intended function. They must be trained in electrical safety procedures and proper use of the instrument. They must be protected from electric shock and contact with hazardous live circuits.
- Maintenance personnel perform routine procedures on the product to keep it operating properly (for example, setting the line voltage or replacing consumable materials). Maintenance procedures are described in the user documentation. The procedures explicitly state if the operator may perform them. Otherwise, they should be performed only by service personnel.
- Service personnel are trained to work on live circuits, perform safe installations, and repair products. Only properly trained service personnel may perform installation and service procedures.

Exercise extreme caution when a shock hazard is present. Lethal voltage may be present on cable connector jacks or test fixtures. The American National Standards Institute (ANSI) states that a shock hazard exists when voltage levels greater than 30 V RMS, 42.4 V peak, or 60 VDC are present.

A good safety practice is to expect that hazardous voltage is present in any unknown circuit before measuring.

Operators of this product must be protected from electric shock at all times. The responsible body must ensure that operators are prevented access and/or insulated from every connection point. In some cases, connections must be exposed to potential human contact. Product operators in these circumstances must be trained to protect themselves from the risk of electric shock.

Before operating an instrument, ensure that the line cord is connected to a properly-grounded power receptacle. Inspect the connecting cables, test leads, and jumpers for possible wear, cracks, or breaks before each use.

When installing equipment where access to the main power cord is restricted, such as rack mounting, a separate main input power disconnect device must be provided in closed proximity to the equipment and within easy reach of the operator.

For maximum safety, do not touch the product, test cables, or any other instruments while power is applied to the circuit under test. ALWAYS remove power from the entire test system and discharge any capacitors before: connecting or disconnecting cables or jumpers, installing or removing switching cards, or making internal changes, such as installing or removing jumpers.

Do not touch any object that could provide a current path to the common side of the circuit under test or power line (earth) ground. Always make measurements with dry hands while standing on a dry, insulated surface capable of withstanding the voltage being measured.

The instrument and accessories must be used in accordance with its specifications and operating instructions, or the safety of the equipment may be impaired.

CAUTION

To maintain protection from electric shock and fire, replacement components in mains circuits - including the power transformer, test leads, and input jacks - must be purchased from Keysight. Standard fuses with

applicable national safety approvals may be used if the rating and type are the same. Other components that are not safety-related may be purchased from other suppliers as long as they are equivalent to the original component (note that selected parts should be purchased only through Keysight to maintain accuracy and functionality of the product). If you are unsure about the applicability of a replacement component, call a Keysight office for information.

- Do not exceed the maximum signal levels of the instruments and accessories, as defined in the specifications and operating information, and as shown on the instrument or test fixture panels, or switching card.
- Chassis connections must only be used as shield connections for measuring circuits, NOT as safety earth ground connections.
- If you are using a test fixture, keep the lid closed while power is applied to the device under test. Safe operation requires the use of a lid interlock.
- Instrumentation and accessories shall not be connected to humans.

WARNING

No operator serviceable inside. Refer servicing to qualified personnel. To prevent electrical shock do not remove covers.

Cleaning Precautions

WARNING

To prevent electrical shock, disconnect the Keysight Technologies instrument from mains before cleaning. Use a dry cloth or one slightly dampened with water to clean the external case parts. Do not attempt to clean internally. To clean the connectors, use alcohol in a well-ventilated area. Allow all residual alcohol moisture to evaporate, and the fumes to dissipate prior to energizing the instrument.

Regulatory Information

The M9217A complies with the following Electromagnetic Compatibility (EMC) compliances:

- IEC 61326-1:2005-12 (EU)
- EN 61326-1:2006
- ICES-001:2004 (Canada)
- AS/NZS CISPR 11:2004

Side panel symbols



The CSA mark is a registered trademark of the CSA International.



The CE marking is the legal required labeling for several EU Directives of the European Union. The CE marking shows that the product complies with all relevant European Legal Directives.



The RCM mark is a Compliance Mark according to the ACMA Labelling Requirement.



The KC mark shows that the product complies with the relevant Korean Compulsory Certification.



This symbol indicates product compliance with the Canadian Interference-Causing Equipment Standard (ICES-001). It also identifies the product is an Industrial Scientific and Medical Group 1 Class A product (CISPR 11, Clause 4).



This symbol indicates the time period during which no hazardous or toxic substance elements are expected to leak or deteriorate during normal use. Forty years is the expected useful life of the product.

Waste Electrical and Electronic Equipment (WEEE) Directive 2002/96/EC

This instrument complies with the WEEE Directive (2002/96/EC) marking requirement. This affixed product label indicates that you must not discard this electrical or electronic product in domestic household waste.

Product category

With reference to the equipment types in the WEEE directive Annex 1, this instrument is classified as a “Monitoring and Control Instrument” product.

The affixed product label is as shown below.



Do not dispose in domestic household waste.

To return this unwanted instrument, contact your nearest Keysight Service Center, or visit www.keysight.com/environment/product for more information.

THIS PAGE HAS BEEN INTENTIONALLY LEFT BLANK.

Table of Contents

Introduction	14
Related documentation	14
Step 1: Unpack and Inspect the Module	15
ESD precaution	15
Inspect the module for damage	16
Return the module for service	17
Step 2: Verify the Shipment Contents	18
Step 3: Install the Software	19
System requirements	19
Power up the controller	20
Install the software	20
Step 4: Install the Module	22
M9217A front panel	26
M9217A system connections	27
Step 5: Verify the Operation of the M9217A Module	28
Conduct performance verification (optional)	29
Specifications	34

THIS PAGE HAS BEEN INTENTIONALLY LEFT BLANK.

List of Figures

Figure 1	Static-safe work station example	15
Figure 2	InstallShield Wizard for Keysight M9217A	21
Figure 3	Installing the module to the chassis	23
Figure 4	Module installation procedures	25
Figure 5	M9217A PXIe 2-CH Digitizer front panel	26
Figure 6	M9217A functional block diagram	27
Figure 7	SFP interface	28
Figure 8	Connecting the calibrator output to the channel inputs on the digitizer	30
Figure 9	Configuring the digitizer	31
Figure 10	Data acquisition and measurement result	32

THIS PAGE HAS BEEN INTENTIONALLY LEFT BLANK.

List of Tables

Table 1	Minimum system requirements	19
Table 2	Required functionality verification hardware	29
Table 3	Configuration for digitizer	31
Table 4	Suggested calibrator output voltages	32

THIS PAGE HAS BEEN INTENTIONALLY LEFT BLANK.

Introduction

The scope of this Startup Guide is to detail the processes of receiving and setting up the Keysight M9217A PXIe 2-CH Digitizer, Isolated, ± 256 V, 20 MSa/s, 16-Bit, installing the required software, and verifying the basic module operation.

If you have any questions after reviewing this information, please contact your local Keysight Technologies representative or contact us through our website at <http://www.keysight.com/find/m9217a>.

Related documentation

A softcopy of this Startup Guide, and the documentation listed below, can be found on the CD-ROM that is shipped with this product. You can also download them for free through our website at www.keysight.com/find/m9217a.

Check the manual revision on the second page of each manual.

- **Keysight M9217A PXIe 2-CH Digitizer, Isolated, ± 256 V, 20 MSa/s, 16-Bit Startup Guide.** This manual. Printed copy for outdoor use, included with shipment.
- **Keysight M9217A PXIe 2-CH Digitizer, Isolated, ± 256 V, 20 MSa/s, 16-Bit Programming Guide.** For IVI-COM console applications.
- **Keysight M9217A PXIe 2-CH Digitizer, Isolated, ± 256 V, 20 MSa/s, 16-Bit Soft Front Panel Software and Help.** Embedded in the Soft Front Panel software.
- **Keysight M9217A PXIe 2-CH Digitizer, Isolated, ± 256 V, 20 MSa/s, 16-Bit Data Sheet**
- **Keysight M9217A PXIe 2-CH Digitizer, Isolated, ± 256 V, 20 MSa/s, 16-Bit Service Guide**

Step 1: Unpack and Inspect the Module

CAUTION

The M9217A is shipped in materials which prevent damage from static. The module should only be removed from the packaging in an anti-static area after ensuring that correct anti-static precautions are taken. Store all modules in anti-static envelopes when not in use.

ESD precaution

Electrostatic discharge (ESD) can damage or destroy electronic components. All work on electronic assemblies should be performed at a static-safe work station. The following figure shows an example of a static-safe work station using two types of ESD protection.

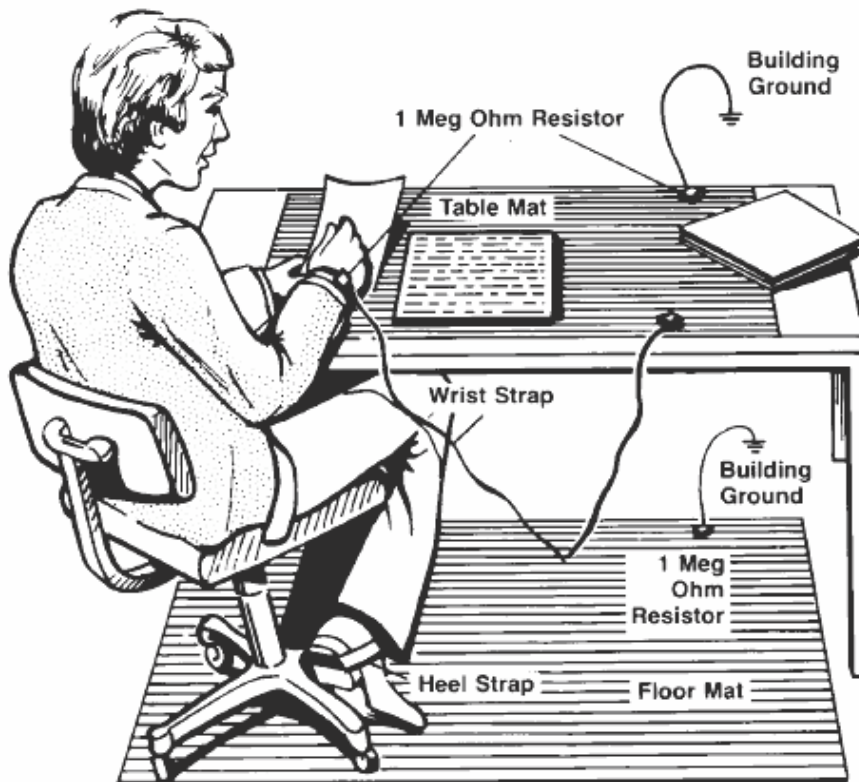

Figure 1 Static-safe work station example

Purchase acceptable ESD accessories from your local supplier.

- Conductive table-mat and wrist-strap combination.
- Conductive floor-mat and heel-strap combination.

Both types, when used together, provide a significant level of ESD protection. Of the two, only the table-mat and wrist-strap combination provides adequate ESD protection when used alone. To ensure user safety, the static-safe accessories must provide at least 1Ω of isolation from ground.

WARNING

These techniques for a static-safe work station should not be used when working on circuitry with a voltage potential greater than 500 V.

Inspect the module for damage

After unpacking the M9217A, carefully inspect the unit for any shipping damage. Report any damage to the shipping agent immediately, as such damage is not covered by the warranty. The warranty also does not cover:

- Damage from contamination
- Normal wear and tear of mechanical components
- Manuals or fuses

(Warranty information can be found at the beginning of this manual.)

CAUTION

To avoid damage when handling a module, do not touch exposed connector pins.

NOTE

Information on preventing damage to your Keysight equipment can be found at www.keysight.com/find/tips.

Return the module for service

Should it become necessary to return the M9217A for repair or service, follow the steps below:

- 1 Review the warranty information shipped with your product.
- 2 Contact Keysight to obtain a Return Material Authorization (RMA) and return address. If you need assistance finding Keysight's contact information, go to www.keysight.com/find/assist (worldwide contact information for repair and service) or refer to the Support information on the product Web page at www.keysight.com/find/m9217a.
- 3 Write the following information on a tag and attach it to the malfunctioning equipment.
 - Name and address of owner. A P.O. box is not acceptable as a return address.
 - Product model number (for example, M9217A).
 - Product serial number (for example, MYXXXXXXXX). The serial number label is located on the side panel of the module. The serial number can also be read from the Soft Front Panel interface, but only after the software is installed.
 - Description of failure or service required.
- 4 Carefully pack the module in its original ESD bag and packing carton. If the original carton is not available, use bubble wrap or packing peanuts and place the instrument in a sealed container and mark the container **“FRAGILE”**.
- 5 On the shipping label, write **“ATTENTION REPAIR DEPARTMENT”** and the RMA number.

NOTE

If any correspondence is required, refer to the product by its serial number and model number.

Step 2: Verify the Shipment Contents

The following items are included in the M9217A shipment:

- *M9217A PXIe 2-CH Digitizer, Isolated, ± 256 V, 20 MSa/s, 16-Bit Software and Product Information CD-ROM* (P/N: M9217-10001) - contains software, drivers, and all product documentation in PDF format
- *M9217A PXIe 2-CH Digitizer, Isolated, ± 256 V, 20 MSa/s, 16-Bit Startup Guide* (P/N: M9217-90001) - printed copy of this document
- Calibration certificate

NOTE

Every PXIe module is shipped with a Software and Product Information CD-ROM. The M9217A-CD1 option provides the M9217A Software and Product Information CD-ROM (M9217-10001).

All files contained in the CD-ROM are available for free download at www.keysight.com/find/m9217a.

Step 3: Install the Software

System requirements

The following table lists the minimum system requirements for Keysight IO Libraries Suite. In general, any x86 or x64 (except Itanium) architecture should work but there may be a significant decrease in performance.

Table 1 Minimum system requirements

Operating systems	Windows® XP SP3 or later (32-bit) Home or Professional	Windows Vista® SP1 and SP2 or later (32-bit and 64-bit) Home Basic, Home Premium, Business, Ultimate, or Enterprise	Windows® 7 (32-bit and 64-bit) Starter, Home Basic, Home Premium, Professional, Ultimate, or Enterprise
Processor speed	600 MHz or higher required 800 MHz recommended	1 GHz 32-bit (x86) or 1 GHz 64-bit (x64), Itanium 64 is not supported	1 GHz 32-bit (x86) or 1 GHz 64-bit (x64), Itanium 64 is not supported
Available memory	256 MB minimum (1 GB or more recommended)	1 GB minimum	1 GB minimum
Available hard-disk space ^[a]	1.5 GB available hard disk space, includes: - 1 GB for Microsoft® .NET Framework 3.5 SP1 ^[b] - 100 MB for Keysight IO Libraries Suite	1.5 GB available hard disk space, includes: - 1 GB for Microsoft® .NET Framework 3.5 SP1 ^[b] - 100 MB for Keysight IO Libraries Suite	1.5 GB available hard disk space, includes: 1 GB for Microsoft® .NET Framework 3.5 SP1 ^[b] 100 MB for Keysight IO Libraries Suite
Video	Super VGA (800 × 600) 256 colors or more	Support for DirectX 9 graphics with 128 MB graphics memory recommended (Super VGA graphics is supported)	Support for DirectX 9 graphics with 128 MB graphics memory recommended (Super VGA graphics is supported)
Browser	Microsoft® Internet Explorer 6.0 or greater	Microsoft® Internet Explorer 7 or greater	Microsoft® Internet Explorer 7 or greater
Chassis	A PXIe or PXI-H chassis peripheral slot. The Keysight M9018A chassis is recommended.		
Interface controller	A PXIe remote or embedded controller.		
Remote controller	A Keysight M9045A ExpressCard interface (for portable laptops) or Keysight M9047A PCIe interface (for desktop PCs) or equivalent PXIe remote controllers running one of the above operating systems.		
Embedded controller	A Keysight M9021A System Interface Card, or equivalent embedded controller running one of the above operating systems. Note: The embedded controller must be compatible with the Keysight M9018A chassis.		

[a] Because of the installation procedures, less memory may be required for the operation than is required for the installation.

[b] .NET Framework Runtime Components are installed by default with Windows Vista and Windows 7. Therefore, you may not need this amount of available disk space.

Power up the controller

If you are using a remote controller, power up the host computer.

If you are using an embedded controller, complete the following steps:

- 1 Install the embedded controller module into a compatible chassis.
 - *Recommended: Keysight M9018A 18 slot PXIe Chassis*
- 2 Connect your I/O peripherals (mouse, keyboard, and monitor).
- 3 Power up the chassis.

Install the software

The M9217A software are located on the bundled CD (M9217-10001). The same software are also available for free download at the Keysight website:

www.keysight.com/find/m9217a.

This installation includes the following:

- Keysight IO Libraries Suite (IOLS), which includes the Keysight Connection Expert.
- Soft Front Panel (SFP), device drivers (IVI-C and IVI-COM, and LabVIEW G), and related user documentation for the M9217A.

NOTE

Each PXIe module has its own device driver (IVI-C and IVI-COM, and LabVIEW G) and soft front panel (SFP) software.

-
- 1 From the CD browser, launch the installer.
 - 2 Follow the installer prompts to install all software and documentation for the M9217A PXIe 2-CH Digitizer, Isolated, ± 256 V, 20 MSa/s, 16-Bit.

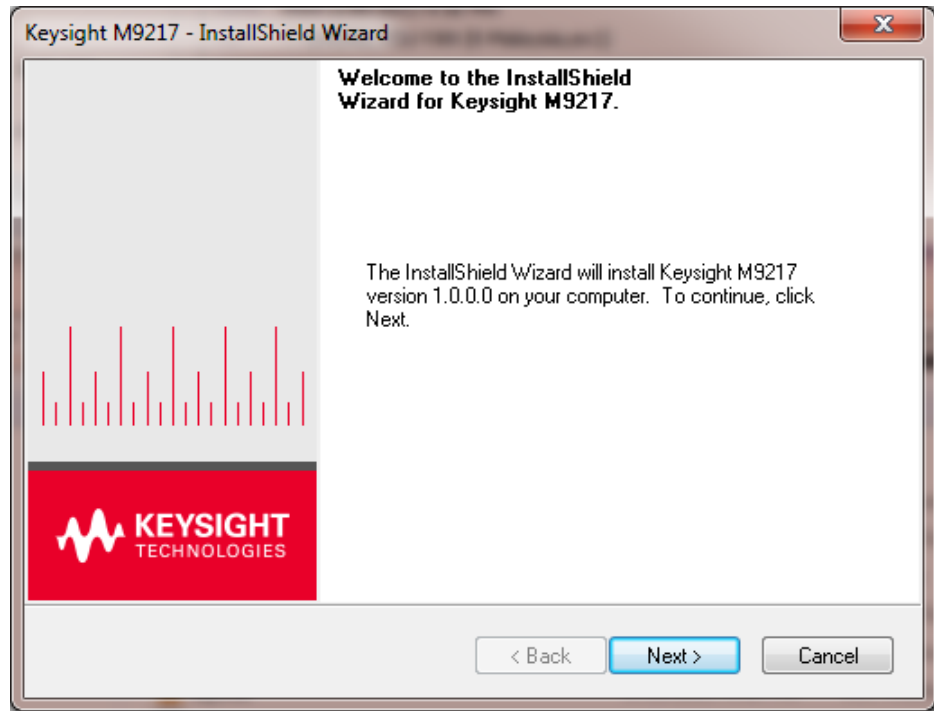

Figure 2 InstallShield Wizard for Keysight M9217A

- 3 After installation is complete, power down the chassis (and the host PC if using the remote controller).

Step 4: Install the Module

CAUTION

- The PXIe hardware does not support “hot-swapping” capabilities (changing modules while power is applied to the chassis).
- Before installing the M9217A into the chassis, ensure that the chassis is powered off and unplugged to prevent damage to the module.

NOTE

The M9217A module can be used in a chassis with a PXIe or PXI-H chassis peripheral slot.

3

The module can be installed in any PXIe slot marked with a peripheral slot compatibility image (a solid circle containing the slot number).

7^H

The module can also be installed in any hybrid PXI slot marked with a peripheral slot compatibility image (the letter “H” and a solid circle containing the slot number).

- 1 Ensure that the chassis power switch is at the Off (Standby) position before you unplug the PXIe chassis.
- 2 If the chassis has multiple fan speed settings, ensure that the fans are set to automatic. Do not set the fan speed to low or turn it off.
- 3 Position the chassis so that there is ample space between the chassis fan intake and exhaust vents. Blockage by walls or obstructions affects the air flow needed for cooling. (Refer to the chassis documentation for more information about cooling).
- 4 If you are using an embedded controller, proceed to **step 5**. If you are using a remote controller, skip to **step 6**.

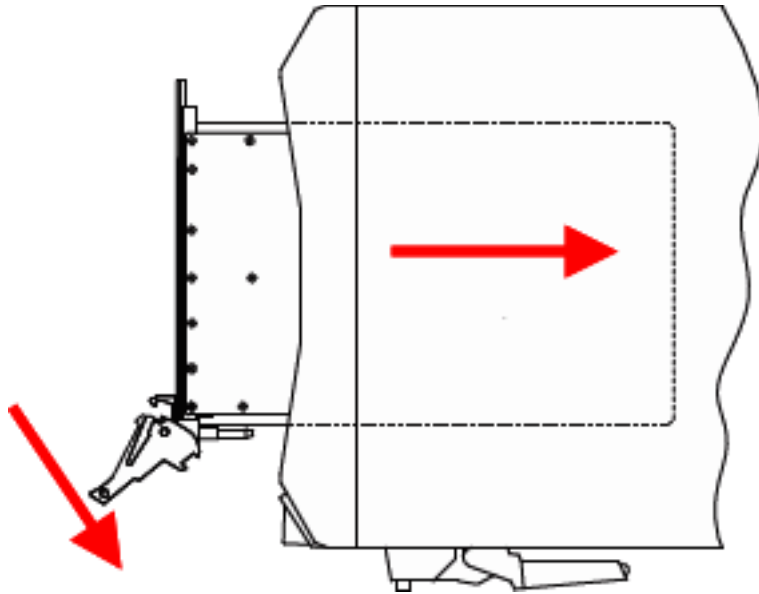

Figure 3 Installing the module to the chassis

- 5 Hold the module by the injector/ejector handle, and slide it into an available PXIe (or hybrid) slot, as shown in **Figure 3**.
 - Install the module into the PXIe slot of the chassis by placing the module card edges into the front module guides (top and bottom).
 - Slide the module to the rear of the chassis and assure that the injector/ejector handle is pushed down in the unlatched (downward) position.
 - Slide the module completely into the chassis.
 - When you begin to feel resistance, push up on the injector/ejector handle to fully inject the module into the chassis.
- 6 If you are using a remote controller, install the System Interface Card in the chassis.
- 7 Latch the module by pulling up on the injector/ejector handle and secure the front panel to the chassis using the module front-panel mounting screws.
- 8 Tighten the screws on the module (or remote controller) front panel. Performance may suffer if the screws are not tightened properly.
- 9 Verify that the PXIe chassis fans are operable and free of dust and other contaminants that may restrict airflow.
- 10 Install all chassis covers and filler panels after installing the module. Missing filler panels may disrupt necessary air circulation in the chassis.
- 11 If you are using a remote controller, connect the System Interface Card in the chassis to host computer.

- 12 Plug in and power up the PXIe chassis.
- 13 If you are using a remote controller, reboot the host PC.

WARNING

Tighten the screws on the module front panel. Protection provided by the equipment could be impaired if the screws are not tightened properly.

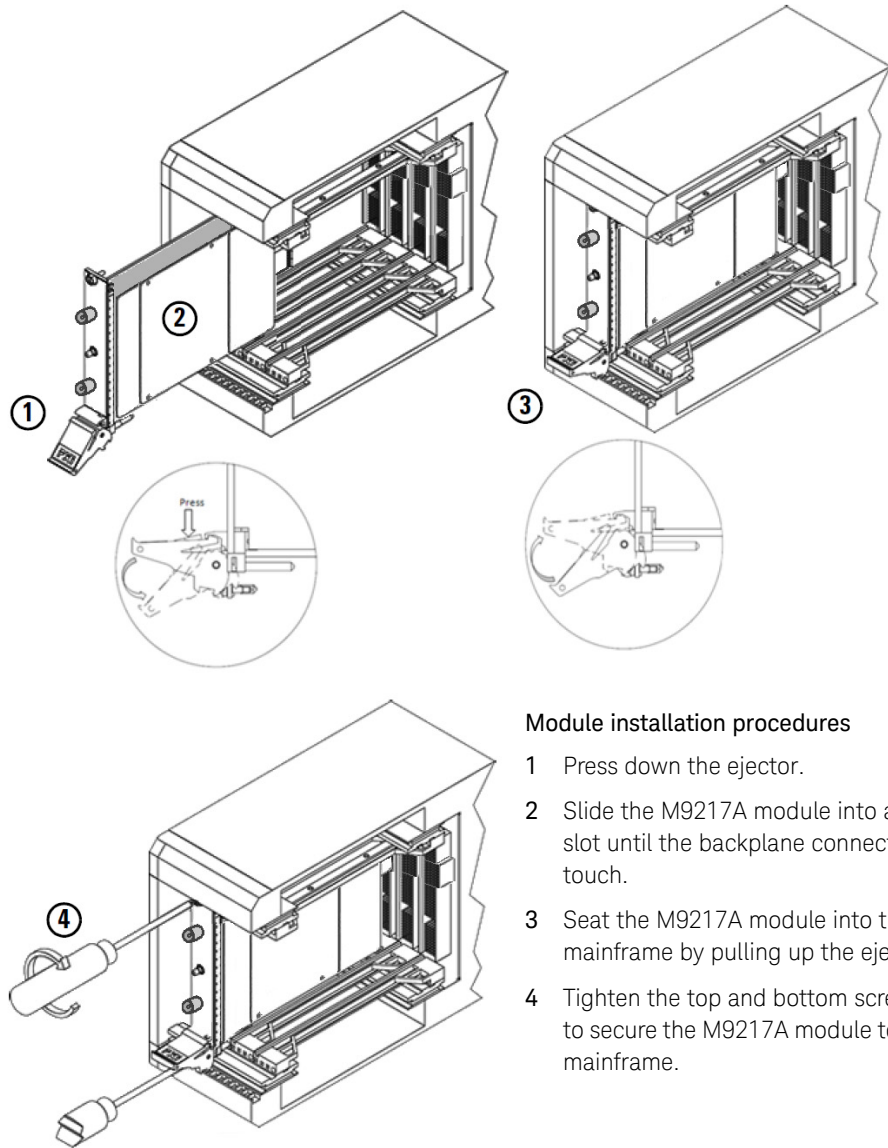

Module installation procedures

- 1 Press down the ejector.
- 2 Slide the M9217A module into any slot until the backplane connectors touch.
- 3 Seat the M9217A module into the mainframe by pulling up the ejector.
- 4 Tighten the top and bottom screws to secure the M9217A module to the mainframe.

Figure 4 Module installation procedures

M9217A front panel



Figure 5 M9217A PXIe 2-CH Digitizer front panel

M9217A system connections

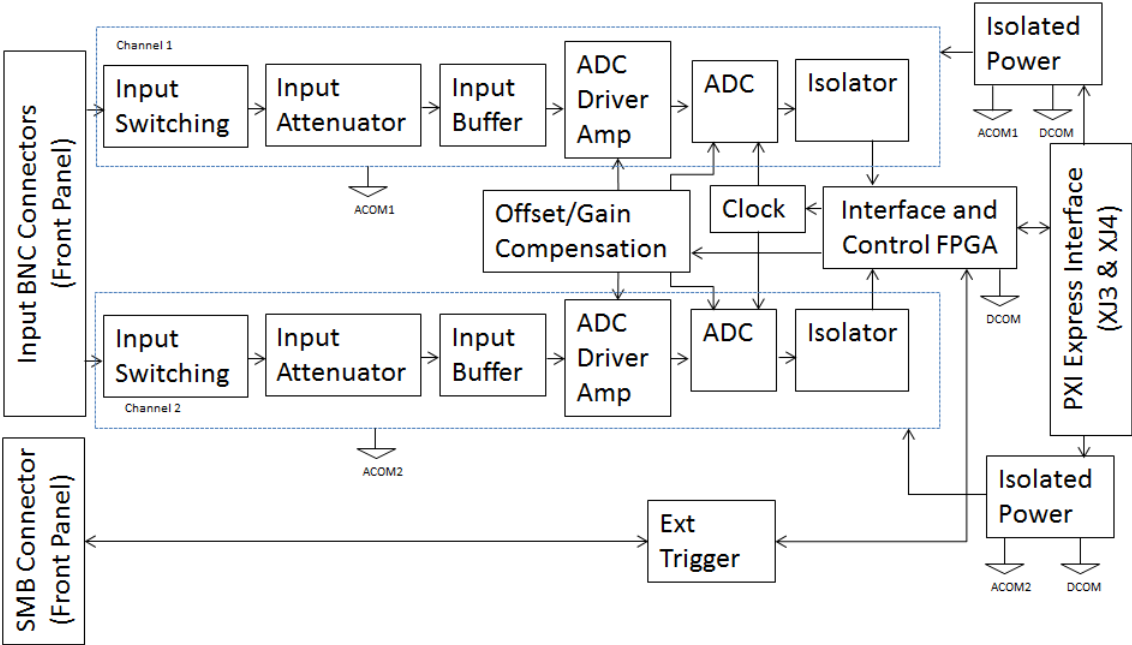

Figure 6 M9217A functional block diagram

Step 5: Verify the Operation of the M9217A Module

The intention of this step is to verify the basic operations of the newly installed module.

Run the Keysight Connection Expert (KCE) by clicking its desktop shortcut icon, or by clicking **Start > All Programs > Keysight IO Libraries Suite > Keysight Connection Expert**.

The KCE will display all modules that are connected and installed. Review the configuration data and launch the M9217A Soft Front Panel (SFP). The M9217A SFP will provide control over the module for operational verification procedures.

This is a screen capture of the SFP interface:

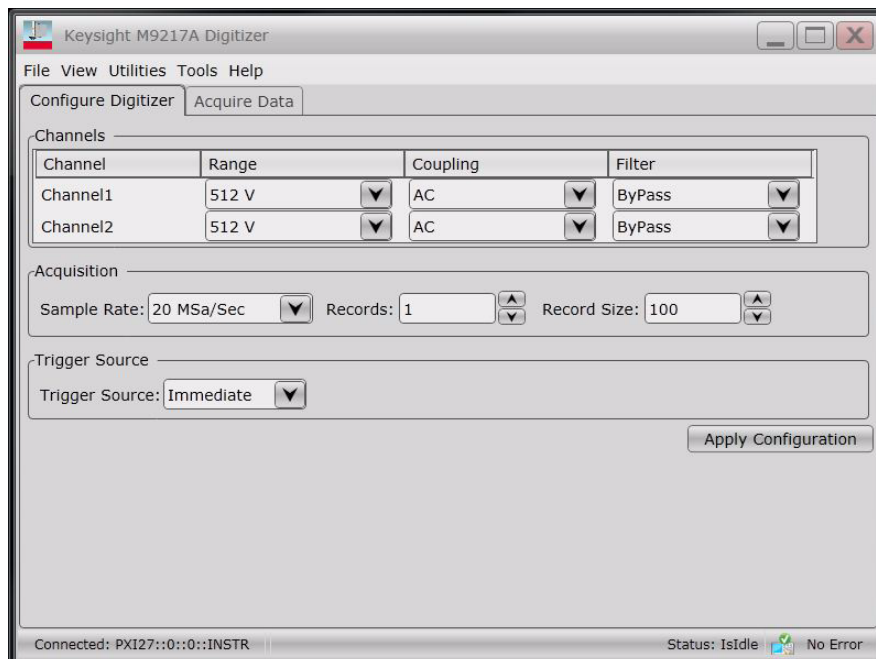

Figure 7 SFP interface

You may use the SFP as a learning tool to help you experience the module's capability and behavior through a user-friendly graphic interface.

You may refer to Keysight *M9217A Soft Front Panel Help* for details on how to use the SFP.

Conduct performance verification (optional)

This procedure verifies the DC accuracy specifications of the digitizer. It can be used to determine if the digitizer meets its published specifications for DC accuracy or if it needs adjustment. It can also be used to verify if the adjustment procedure was successful in adjusting the accuracy of the digitizer to meet its published specifications.

Required hardware

Verifying the functionality of the module requires external equipment. Refer to **Table 2** for the recommended functionality verification hardware.

Table 2 Required functionality verification hardware

Hardware	Description
PXIe chassis	PXIe requirements
PXIe slot-1 controller	
Fluke 5700A	Multifunction calibrator

M9217A verification procedure

The DC accuracy verification procedure uses a calibration standard of known accuracy to generate DC voltage input signals that are measured by the digitizer. You are required to calculate the average value from the measured data samples. The measurement results (average) are then compared to the known values of the inputs to determine the measurement error of the digitizer. Large data records are acquired and averaged in order to reduce the effects of noise on the measurements and to determine the DC value of the input signals more accurately.

- 1 Run M9217A Soft Front Panel (SFP).
- 2 Connect the calibrator output to the channel inputs on the digitizer. Both channels may be connected in parallel to make the measurements easier. Use BNC T-connectors near the channel inputs.

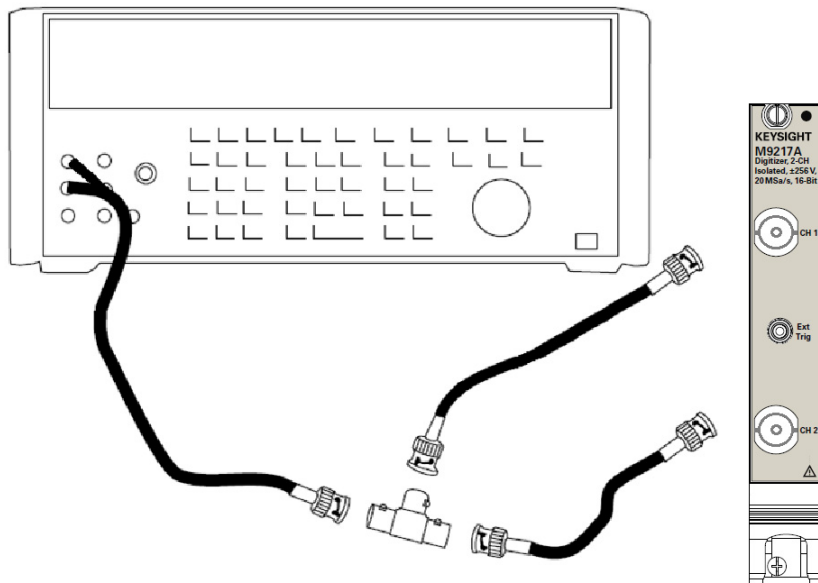

Figure 8 Connecting the calibrator output to the channel inputs on the digitizer

- 3 Configure the digitizer using SFP as shown in **Table 3** or **Figure 9**.

Table 3 Configuration for digitizer

Settings	Description	Specification
Channels	Channel	1
	Range	500 mV (± 250 mV)
	Coupling	DC
Acquisition	Sample rate	20 MSa/s
	Number of records	1
	Record size	20000
	Trigger holdoff	0 sec
	Pre-trigger samples	0
	Trigger delay	0
Trigger source	Immediate	

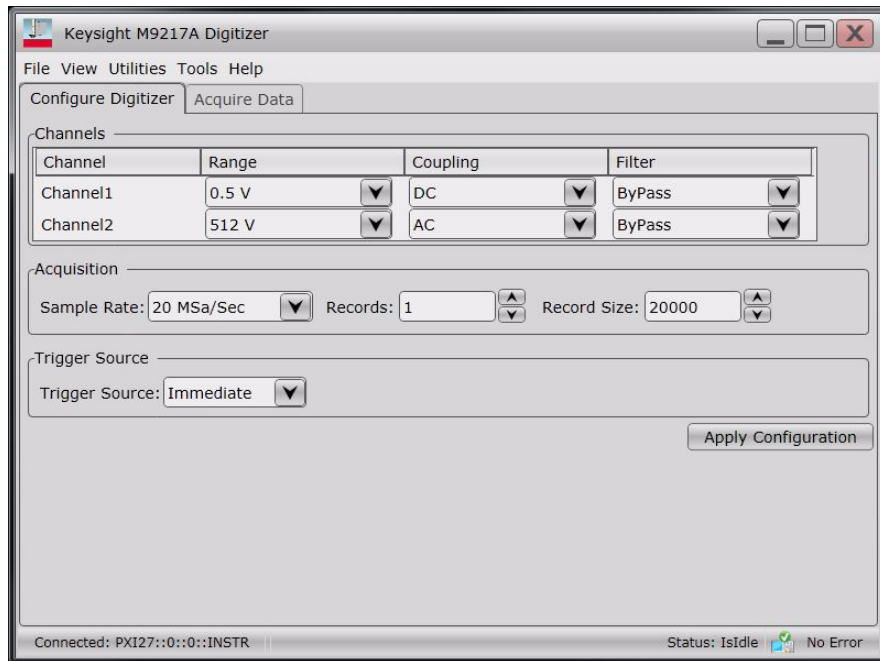

Figure 9 Configuring the digitizer

- 4 Set the calibrator to output -0.235 V.
- 5 On the M9217A PXIe 2-CH Digitizer SFP, click on the **Acquire Data** tab. Click on **Single** to measure. The result will be displayed as shown in Figure 10.

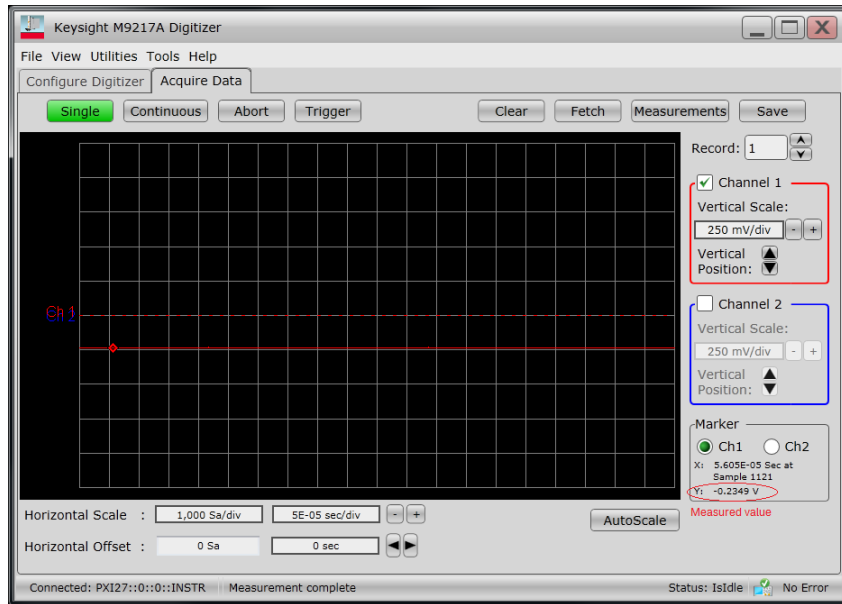

Figure 10 Data acquisition and measurement result

- 6 Compare the measured values to the accuracy as stipulated in the specifications.
- 7 Repeat **step 3** to **step 5** for all voltage range and channels. Refer to the following table for the list of suggested calibrator output voltages.
- 8 If any values are out of range, refer to “**Return the module for service**” on page 17 for details on sending the module to Keysight Technologies for service.

Table 4 Suggested calibrator output voltages

Input value	Channel range	Error from input	Input value	Channel range	Error from input
-235 mV	250 mV	+/-0.000985 V	-15.2 V	16 V	+/-0.0344 V
0 V		+/-0.00075 V	0 V		+/-0.0192 V
+235 mV		+/-0.000985 V	+15.2 V		+/-0.0344 V
-460 mV	500 mV	+/-0.00146 V	-30.4 V	32 V	+/-0.0688 V
0 V		+/-0.0010 V	0 V		+/-0.0384 V
+460 mV		+/-0.00146 V	+30.4 V		+/-0.0688 V
-950 mV	1 V	+/-0.00215 V	-60.8 V	64 V	+/-0.2528 V
0 V		+/-0.0010 V	0 V		+/-0.192 V
+950 mV		+/-0.00215 V	+60.8 V		+/-0.2528 V

Table 4 Suggested calibrator output voltages

Input value	Channel range	Error from input	Input value	Channel range	Error from input
-1.9 V	2 V	+/-0.0043 V	-121.6 V	128 V	+/-0.3776 V
0 V		+/-0.0024 V	0 V		+/-0.256 V
+1.9 V		+/-0.0043 V	+121.6 V		+/-0.3776 V
-3.8 V	4 V	+/-0.0158 V	-237.5 V	256 V	+/-0.5447 V
0 V		+/-0.012 V	0 V		+/-0.3072 V
+3.8 V		+/-0.0158 V	+237.5 V		+/-0.5447 V
-7.6 V	8 V	+/-0.0236 V			
0 V		+/-0.016 V			
+7.6 V		+/-0.0236 V			

NOTE

The table uses the calibrator zero output for ease of connection. A more accurate verification of the zero can be obtained by connecting a 50 Ω termination to the input connectors.

WARNING

Shock Hazard. This procedure requires the application of up to 240 Vdc. Ensure all test connections are properly insulated and shielded.

Specifications

Complete specifications for the M9217A (*M9217A Data Sheet, 5992-0366EN*) are included on the *Keysight M9217A Software and Product Information CD-ROM* that came with your module. Please check the Keysight website at www.keysight.com/find/m9217a for the latest updates on these specifications.

THIS PAGE HAS BEEN INTENTIONALLY LEFT BLANK.



This information is subject to change without notice. Always refer to the English version at the Keysight website for the latest revision.

© Keysight Technologies 2015

Edition 1, October 1, 2015



M9217-90001

www.keysight.com